

ensoniq®



SOUNDSCAPE™
BY ENSONIQ

ES 5706 "ODIE"

ENSONIQ Soundscape Multimedia PC Host Interface

TABLE OF CONTENTS

Section 1 - Introduction and Specifications

1.1	Introduction	2
1.2	Specifications	2

Section 2 - Host PC Interface

2.1	Host PC Interface Overview	5
2.2	Host I/O Address Decoder.....	5
2.3	Host Interrupt Interface	6
2.4	Host DMA Interface.....	6

Section 3 - On-Board Processor Interface

3.1	On-Board Processor Interface Overview	8
3.2	On-Board Processor Address Decode.....	8
3.3	On-Board Processor OTIO Interface	8
3.4	On-Board Processor Interrupt Interface.....	9
3.5	On-Board Processor DMA Interface	9
3.6	Host-to-RAM DMA Operations.....	9
3.7	RAM-to-Host DMA Operations.....	10
3.8	On-Board Processor Operating Code Download	10
3.9	Sound Memory Interface	11

Section 4 - Analog Section Functional Description

4.1	Analog Section Overview.....	13
4.2	D/A Converter and Output Anti-Aliasing Filters	13
4.3	Audio Mixer.....	13
4.4	A/D Converter and Input Anti-Aliasing Filters.....	13

Section 5 - Register and Pinout Maps.....15

SECTION 1 -INTRODUCTION AND SPECIFICATIONS

1.1 INTRODUCTION

The Soundscape™ multimedia audio board is a full Microsoft Level I-compatible audio subsystem based on the ENSONIQ OTTO digital oscillator chip, the Sequoia Development Group ODIE support gate array and the Sequoia Mockingbird-OTTO firmware. OTTO provides up to thirty-two voices of CD-quality 16-bit digitally synthesized sounds at sample rates ranging from a few kHz to well beyond 44 kHz. With ODIE, OTTO's companion gate array, and the Mockingbird-OTTO synthesizer firmware, the Soundscape board exceeds all requirements of the Level I specification.

By careful design and exploitation of the unique combination of features found in OTTO, Soundscape provides very high performance, and a high degree of flexibility in configuration while maintaining a low production cost and low parts count. In fact, Soundscape actually has a lower production cost than some existing Level I audio boards based on the Yamaha YM3812 and OPL-III FM synthesizers.

To maintain maximum compatibility with existing software, the PC interface of Soundscape exactly emulates a Roland MPU-401 MIDI interface, including the "intelligent" mode. With the addition of a Yamaha YM-3812 2-operator FM synthesizer or OPL-III 4-operator FM synthesizer the Soundscape provides an exact emulation of the Creative Labs SoundBlaster, including the DSP interface for voice and MIDI, thus providing 100% compatibility with existing game software.

1.2 SPECIFICATIONS

SYNTHESIZER SECTION:

Architecture:	Digital Wavetable Synthesizer
Voices:	Up To 32
Polyphony:	Up To 32 Notes
Sample Memory:	Up To 8 Mwords of ROM/SRAM/DRAM
D/A Converter:	16-Bit Linear Serial
Maximum Playback Rate:	44.1 kHz
Level And Panning Controls:	Separate 12-Bit L&R Controls For Each Voice
Filters:	Separate Configurable 4-Pole Digital Filter For Each Voice
Envelopes:	Hardware Envelopes For Amplitude and Filters
Effects:	Optional DSP Multiple Effects Processor
Firmware:	Sequoia Mockingbird-OTTO

FM SYNTHESIZER:

Synthesizer:	Yamaha YM-3812 2-Operator FM or OPL-III 4-Operator FM
Number of Voices:	11 (YM3812) or 20 (OPL-III)
Base Port Address:	228H, 238H or 248H, and/or 388H

PCM PLAYBACK SECTION:

Capability: Simultaneous Playback Of Two Mono Or Stereo Streams
D/A Converter: 16-Bit Linear Serial
Maximum Playback Rate: 44.1 kHz
Level And Panning Controls: Separate 12-Bit L&R Controls For Each Channel
Filters: Separate Configurable 4-Pole Digital Filter For Each Channel
Data Formats: 8-, 12- or 16-Bit Signed Or Unsigned, 8-Bit -Law
Compressed. All Formats Either Mono Or Interleaved Stereo

DIGITAL RECORDING SECTION:

Capability: Mono or Interleaved Stereo Recording
A/D Converter: 16-Bit Linear Serial Delta-Sigma Converter
Available Sampling Rates: 44.1, 22.05, 11.025 kHz +/-0.1%
Source Selection: Any Source(s) Via Separate Stereo Record Mixer
Level Control: Individual Software Controls For Each Source
Level Control Range: +30 To 0 dB On Microphone Input
0 To -38 dB On All Other Sources
Anti-Aliasing Filter: Digital Decimation Filter
Data Formats: 8-, 12- or 16-Bit Signed Or Unsigned, or 8-Bit -Law
Compressed. All Formats Either Mono Or Interleaved Stereo

AUDIO MIXING SECTION:

Input Sources: Synthesizer Output, FM Synthesizer Output, PCM Output,
Internal Line Input (CD), External Line Input, MIC Input
Output Configuration: Line Level To 3.5mm Mini-Phone Jack (HeadPhone or
Speaker Power Amplifier Optional)
Output Level: Approx. 4V p-p Maximum
Level Control: 12-Bit For Synthesizer & PCM, 5-Bit For All Others
Level Control Range: +0 To -96 dB For Synthesizer & PCM
+0 To -34 dB For All Others
Frequency Response: 20-20,000 Hz +/- 1 dB All Inputs
Distortion: < 0.5% All Inputs
Signal/Noise Ratio: > 80 dB All Inputs

HOST INTERFACE:

Configuration: Emulation of MPU-401 Or 68B50 UART-Based MIDI
Interface
Number of Ports: 2
Base Port Address: Software Selectable from 320H, 330H, 340H, 350H
Interrupt Usage: 1, 2, or 3 Software Selectable From 4
DMA Usage: 1, 2, or 3 Channels, Software Selectable From 6
CD-ROM Interface: I/O Decode, Bus Buffering and Software DMA and Interrupt
Selections Provided For AT-Bus/SCSI Controller

MIDI INTERFACE:

Number of Ports: 1
Connections: 1 IN, 2 OUT, 1 THRU (with optional expander)
MIDI Clock: 12-Bit, 1 MHz Counter With Synchronized Tempo Updates
Software Features: MIDI Split, Merge And Time-Stamp

Ensoniq ODIE Specification

JOYSTICK INTERFACE:

Configuration: Standard IBM Compatible Analog Joystick Interface
Number of Joysticks: 2 (4 Axes, 4 Buttons)

ON-BOARD PROCESSOR:

Processor: 8 MHz Motorola 68EC000
Dedicated ROM: None, All Operating Code Downloaded From Host PC
Dedicated RAM: None, All RAM Is Shared With OTTO Sound Memory

SECTION 2 - HOST PC INTERFACE FUNCTIONAL DESCRIPTION

2.1 HOST PC INTERFACE OVERVIEW

Refer to Figure 1, Host PC Interface Block Diagram, at the end of this section for the following discussions. The host PC interface consists of a group of 6 to 40 I/O ports. The first two of these ports access an emulation of one of two standard Musical Instrument Digital Interface (MIDI) interfaces: a 68B50-based UART, or a Roland MPU-401, both of which are widely supported by available MIDI software. The next two ports provide a second interface identical in functionality to the emulated MIDI port. This port is generally used for communicating command and status information to the On-Board Processor (OBP), but can also be used to provide emulation of a dual-port MIDI interface. In this configuration, one port could be used to drive the on-board synthesizer, while the second is used to drive an external synthesizer. The next two host interface ports consist of a data port, and an address port, used to select which of the internal registers will be accessed next through the data port. Through this interface, the host CPU can communicate with the on-board processor as well as some of ODIE's internal control and status registers. This architecture allows future expansion of the host register set without requiring a larger block of host I/O addresses, or loss of upward/downward compatibility. Address decoding, data bus buffering, and software selectable IRQ and DMA channel selection are provided for addition of an AT-bus or SCSI controller. The CD-ROM interface can be decoded for 2, 8, 16 or 32 consecutive port addresses.

In addition to the above I/O ports, the host interface uses one or two interrupt levels, and one or two DMA channels. The CD-ROM interface may also use a single interrupt level and DMA channel. Interrupt levels are software selectable from four choices (normally IRQ 2, 7, 12 & 15), while DMA channels are software selectable from six choices (normally 0, 1, 3, 5, 6, & 7). The interrupt and DMA control lines are tri-state-able so that the interrupt and DMA channels can be shared by other "well-behaved" peripherals. In particular, this architecture allows multiple Soundscape boards to be operated in a single PC, sharing the same interrupt and DMA channels. All communications with the host PC are either interrupt- or DMA-driven. In addition, the polarities and protocols for all interrupt and DMA signals are configurable to support a wide variety of host bus interfaces. It would be a simple matter, for example, to adapt the Soundscape design to a Macintosh, Amiga or any other popular computer.

All host interface logic is contained inside ODIE, except for a pair of 74LS245 data bus buffers and a few control and address line buffers. The base address decode for the board is jumper selectable to 320H, 330H, 340H, or 350H.

All I/O operations are performed without incurring wait states, and all data transfers are buffered by ODIE, to virtually eliminate any potential source of incompatibility related to I/O channel timing. All host read data is driven by ODIE, through the 74LS245 data bus buffers, and all write data is latched in ODIE on the rising edge of IOW*, thus making all I/O operations virtually oblivious to I/O bus speed in any machine which is even remotely IBM compatible.

2.2 HOST I/O ADDRESS DECODER

The host PC I/O address decoding logic allows the base port address of the Soundscape to be set to 320H, 330H, 340H or 350H. Host address bits 0-2 are decoded to select the specific register to be accessed as indicated in the following table:

BASE+0	MIDI Emulation Control Register
BASE+1	MIDI Emulation Data Register
BASE+2	HOST Interface Control Register
BASE+3	HOST Interface Data Register
BASE+4	ODIE Internal Address Register
BASE+5	ODIE Internal Data Register

2.3 HOST INTERRUPT INTERFACE

The host interrupt level (IRQ) used by ODIE is selectable under software control. Any of four IRQ's can be made software selectable. Generally IRQs 2, 7, 10, 11, 12 and 15 are available. The current default selection is IRQs 2, 7, 12 & 15. ODIE is capable of generating interrupts on any of the following conditions, each of which is separately maskable:

MIDI Emulation RxRDY
MIDI Emulation TxRDY
HOST Interface RxRDY
HOST Interface TxRDY
DMA Terminal Count Reached
MIDI Clock

In addition to the individual interrupt enables, there is also a master enable to completely disable all interrupts at once.

The IRQ lines may be configured to operate in a "sharable" fashion, being tri-stated when not in use, so other boards may share the same interrupt channel if required. In addition, each interrupt is individually configurable as active high, active low or edge triggered, for maximum flexibility, and to permit easy integration of the Soundscape into non-IBM systems.

2.4 HOST DMA INTERFACE

The specific DMA channel(s) to be used by the board are software selectable. Any 3 of 6 DMA channels are software selectable. The current selection is channels 0, 1, 3, 4, 5, & 6. In general, an 8-bit DMA channel would be used for all 8-bit DMA transfers, and a 16-bit channel would be used for all 12- and 16-bit transfers. To support operation in XT-class machines, ODIE supports 12- and 16-bit transfers over 8-bit DMA channels. ODIE does not, however, support 8-bit transfers over 16-bit DMA channels. ODIE also allows data to be input in one format, and output in a different format, so that, for example, an 8-bit -Law compressed PCM file can be created from a 16-bit signed PCM file by transferring the data to ODIE in 16-bit signed format, and sending it back to the host in compressed format. Using both 8- and 16-bit DMA channels optimizes DMA throughput, and minimizes host CPU overhead.

Since the OTTO memory architecture only allows external access to the sample DRAM on alternate cycles, burst DMA mode is not supported. Instead, single cycle transfers are made, and host transfers are interleaved with OTTO accesses, with all data being buffered by ODIE. The DMA interface is implemented in a "sharable" fashion, with the DRQ line(s) being tri-stated when not in use, so other boards may share the same DMA channel(s) if required. The DRQ and DACK polarities are also programmable for maximum flexibility.

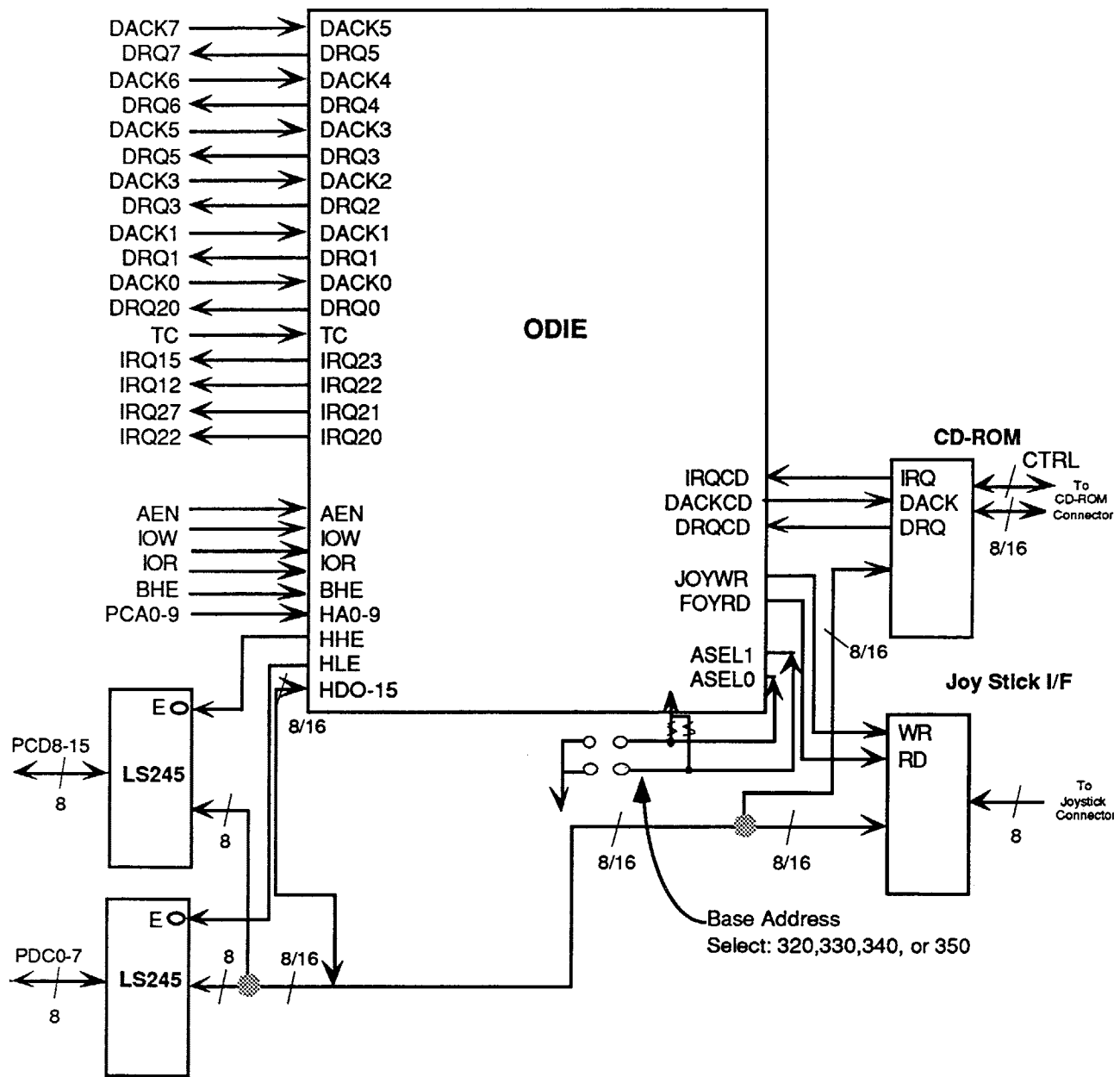

Figure 1 - Host PC Interface Block Diagram

SECTION 3 - ON-BOARD PROCESSOR INTERFACE FUNCTIONAL DESCRIPTION

3.1 ON-BOARD PROCESSOR INTERFACE OVERVIEW

Refer to Figure 2, On-Board Processor Interface Block diagram, at the end of this section for the following discussion. The 68EC000 on-board processor (OBP) interface provides all required I/O and memory decoding, DTACK generation, data buffers and latches, and all required system timing and control signals. All of this interface logic is contained within ODIE, along with all of the required peripherals such as the UART for the MIDI interface, the MIDI clock timer, and an interrupt timer. In fact, the only LSIs are the CPU itself, and ODIE. There are no dedicated ROMs for the OBP, as all operating code is downloaded into the on-board DRAM/SRAM via DMA prior to releasing the OBP from reset. A completely ROM-based system can be easily built, however.

3.2 ON-BOARD PROCESSOR ADDRESS DECODE

The 16 Mbyte OBP memory space is divided by ODIE into four segments of 4 Mbytes each by decoding the 2 highest address bits. The segments are mapped as follows:

Segment 0	000000-3FFFFFFH	Memory Device 0 (RAM)
Segment 1	400000-7FFFFFFH	Selectable Memory Bank
Segment 2	800000-9FFFFFFH	OTTO Internal Registers
	A00000-BFFFFFFH	ODIE Internal Registers
Segment 3	C00000-FFFFFFH	Selectable Memory Device

Segment 0 always maps to memory device 0, which will almost always be either DRAM or SRAM. This is required to support PCM playback. Segment 1 can be mapped to any of the four 4Mbyte banks of OTTO memory space. Segment 2 accesses OTTO and ODIE internal registers. Segment 3 maps to a selectable memory device, which would usually be device 0. This is done to allow the 68000 "short" addressing mode to be used, which not only reduces the code size, but also improves performance.

3.3 ON-BOARD PROCESSOR OTTO INTERFACE

OTTO is operated in "slave" mode, allowing ODIE to control all memory accesses. ODIE generates separate CAS*/CS* signals for up to 4 memory devices, each of which can be either SRAM/ROM or DRAM, as well as two WE* signals to allow the OBP byte-access to sound memory. For ROM/SRAM banks, RAS* is used to drive the OE* pins of all memory devices. The memory decoding logic supports any combination of up to 4 DRAMs/SRAMs/ROMs. DRAM configurations from as little as 64Kx8 up to the maximum 8Mx16 can be supported with no additional external logic. The type and configuration of memory actually installed can be determined automatically by the OBP during initialization.

The OBP communicates with the OTTO registers through the OTTO host bus with ODIE generating the required request signal (CSB) to the OTTO.

3.4 ON-BOARD PROCESSOR INTERRUPT INTERFACE

All interrupts to the OBP are processed by ODIE. ODIE can generate separately vectored interrupts on the following conditions, listed in order of decreasing priority:

INTERRUPT SOURCE	VECTOR NUMBER	PRIORITY LEVEL
MIDI Interface RxRDY/TxRDY	47H	6
OTTO Interrupt	46H	5
HOST Interface RxRDY/TxRDY	45H	4
MIDI Emulation RxRDY/TxRDY	44H	4
Interrupt Timer	43H	3
DMA A Or B Complete	42H	2
MIDI Clock	41H	1
SMPTE/MIDI RxRDY	40H	1

Each interrupt has a separate enable, and a master interrupt enable is also provided.

3.5 ON-BOARD PROCESSOR DMA INTERFACE

The DMA control logic, which is completely contained within ODIE, consists of two independent DMA controllers. Several different DMA modes are supported to allow DMA from host to RAM (for loading samples and PCM data), and DMA from RAM to host (primarily for A/D recording). All modes are capable of transferring 8-, 12- or 16-bit data, as appropriate. In addition, there are sub-modes available which largely automate PCM and A/D data transfers. In fact, continuous A/D recording is possible with no assistance from the OBP, once the initial transfer is started. Each of these modes is discussed in more detail in the following sections.

The host DMA channel to be used is programmed by the host CPU before each transfer begins, in order to make it possible to use both 8-bit and 16-bit DMA channels. All operations may be carried out over 8- or 16-bit DMA channels, with the exception of 8-bit DMA over a 16-bit DMA channel, which is not supported.

3.6 HOST-TO-RAM DMA OPERATIONS

Host-to-RAM DMA is used both for loading samples and parameters into the sample DRAM, as well as for loading PCM data into buffers in the RAM.

For sample loads, a 16-bit DMA channel is generally used, and transfers start at the address programmed by the OBP into the DMA address register, and end when terminal count is reached. Terminal count can generate an interrupt to the OBP and/or the host CPU.

For PCM data transfers, there are several different options as to how the transfer takes place, since 8-, 12- and 16-bit data must be handled, as well as both mono and interleaved stereo data. Also, the timing of transfers has to be coordinated by the OBP to ensure a buffer is not written to while it is being played.

All PCM transfers take place into circular buffers 4K samples in length. For a mono PCM playback, there is one buffer, while for stereo PCM playback there are two buffers, one for each channel. These buffers MUST be located on consecutive 4K sample boundaries in the sample

DRAM. Each 4K buffer is actually treated as two consecutive 2K buffers. Before playback starts, the entire 4K is pre-loaded. The OTTO is then programmed by the OBP to play a 4K forward loop, and interrupt on end of loop. The OBP calculates the time required to play the first 2K samples, and when that time has elapsed, triggers the DMA to refill the first 2K of the buffer. When the OBP receives the loop end interrupt from OTTO, it triggers the DMA to refill the second half of the buffer. This process continues until PCM playback is stopped.

In order to save the OBP from having to constantly update the DMA address register, and to reduce the DMA overhead on the host CPU, the DMA address counter is able to automatically stop itself after 2K transfers, and automatically reset the address to the start of the buffer after 4K transfers. In this way, the OBP need only tell the DMA hardware when to start the next transfer. The host DMA can also be programmed for a large block size, and the DMA can proceed at it's own pace, not requiring any processor intervention to know when to stop.

If stereo PCM data is being transferred, the process is very similar to that described above, except two consecutive 4K buffers are allocated, and the DMA hardware automatically de-interleaves the data into two separate buffers. Each transfer terminates when 2K samples have been transferred into each buffer (4K samples total). In this way, stereo PCM can be handled with no additional overhead on the OBP.

For 8- and 12-bit PCM transfers, the procedures are exactly as described above, except ODIE always forces the low byte or low nibble of each word to zeroes. Since OTTO expects PCM data to be in signed format, and the Level I standard specifies unsigned format for 8-bit PCM data, ODIE provides the option of unsigned-to-signed conversion of the data on-the-fly.

3.7 RAM-TO-HOST DMA OPERATIONS

RAM-to-host DMA is used primarily for transferring sampled (A/D) data to the host. A/D data is buffered in RAM in essentially the same manner as described above for PCM data. However, since ODIE controls the timing of A/D transfers, it is not necessary for the OBP to trigger the DMA. A DMA transfer is automatically initiated as soon as a buffer is half full (2K samples stored).

As a safety precaution, a status flag is set, and can be read by the OBP, if the A/D buffer overflows. This allows the OBP to notify the host CPU that the sampled data may be corrupt.

3.8 ON-BOARD PROCESSOR OPERATING CODE DOWNLOAD

In order to allow the OBP to be ROMless, ODIE allows the host to DMA data directly into the RAM while the OBP is inhibited. As explained above, during a normal host-to-RAM DMA, ODIE generates RAM addresses, and all required RAM control signals. By providing a means for ODIE to initiate DRAM refresh without CPU support, the existing DMA logic can be used to load the OBP code into RAM or DRAM. This is accomplished by a control bit within ODIE which forces all OTTO RAM accesses (which take place when the OTTO E clock is high) to be CAS before RAS refresh cycles. Once the OBP has initialized the OTTO to perform normal refresh, this mode is disabled.

3.9 SOUND MEMORY INTERFACE

ODIE directly supports up to four memory devices, each of which may be static or dynamic, and each of which may range in size from 64K to 4M. ODIE provides properly latched and/or multiplexed addresses, and CAS*/CS* for all devices. To support this flexibility, three address busses, and five CAS*/CS* lines are provided. The address connections for dynamic memory devices are as follows:

ODIE Signal	64Kb Device	256Kb Device	1Mb Device	4Mb Device
XA0	A0/A8	A0/A17	A0/A19	A0/A19
XA1	A1/A9	A1/A9	A1/A18	A1/A18
XA2	A2/A10	A2/A10	A2/A10	A2/A20
XA3	A3/A11	A3/A11	A3/A11	A3/A11
XA4	A4/A12	A4/A12	A4/A12	A4/A12
XA5	A5/A13	A5/A13	A5/A13	A5/A13
XA6	A6/A14	A6/A14	A6/A14	A6/A14
XA7	A7/A15	A7/A15	A7/A15	A7/A15
XA8	---	A8/A16	A8/A16	A8/A16
XA9	---	---	A9/A17	A9/A17
XA10	---	---	---	A10/A21

The address connections for static memory devices are as follows:

ODIE Signal	ROM or SRAM
OA0	A0
OA1	A1
OA2	A2
OA3	A3
OA4	A4
LA5	A5
LA6	A6
LA7	A7
LA8	A8
LA9	A9
XA0	A19
XA1	A18
XA2	A20
XA3	A11
XA4	A12
XA5	A13
XA6	A14
XA7	A15
XA8	A16
XA9	A17
XA10	A10
OA21	A21
OA22	A22

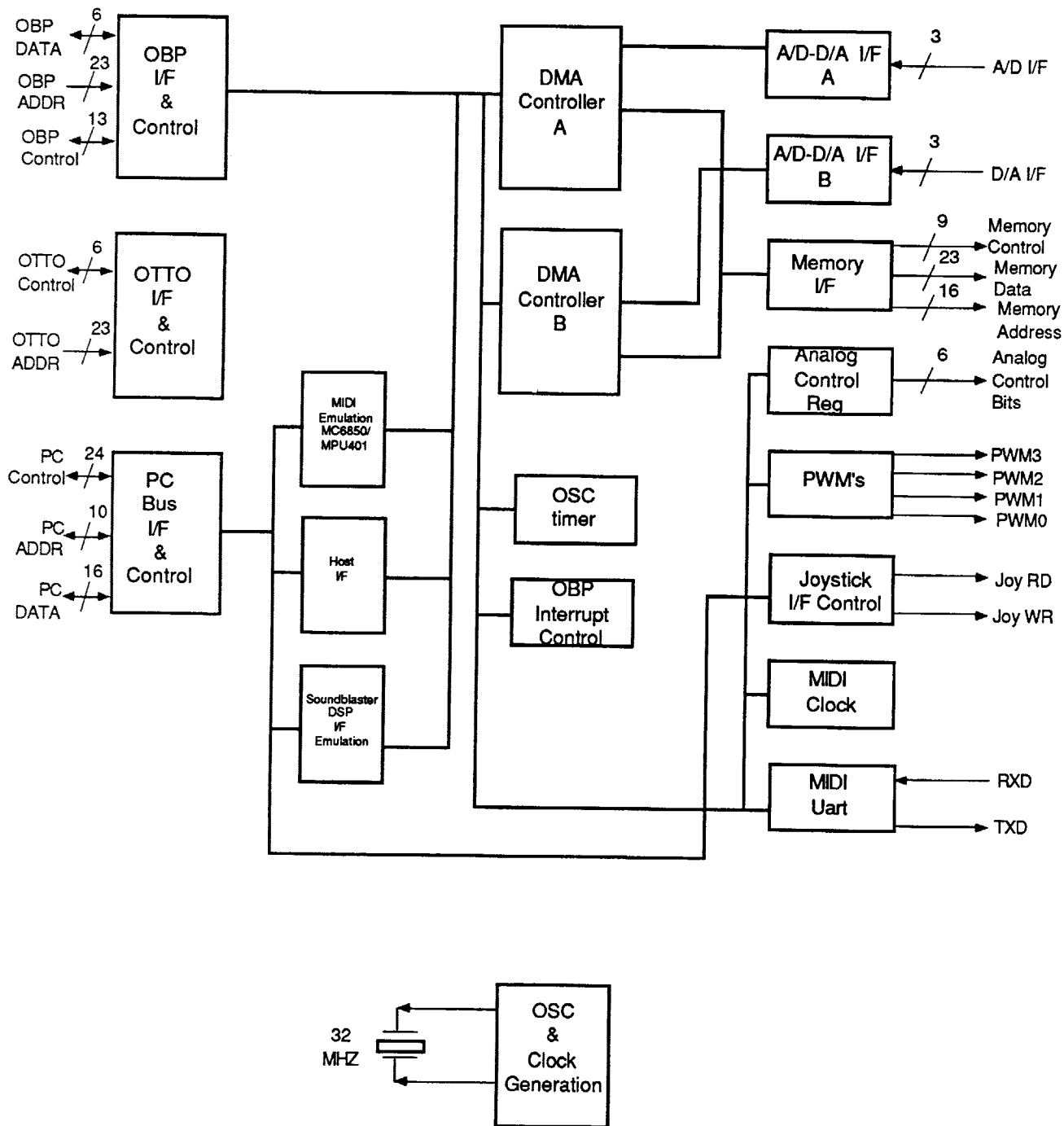

Figure 2 - On-Board Processor Interface Block Diagram

SECTION 4 - ANALOG SECTION FUNCTIONAL DESCRIPTION

4.1 - ANALOG SECTION OVERVIEW

Refer to Figure 3, Analog Section Block Diagram, at the end of this section for the following discussion. The analog section of the Soundscape consists of three major sections: i) the OTTO output anti-aliasing filters, ii) the mixer, and iii) the input anti-aliasing filters and A/D converter.

4.2 - D/A CONVERTER AND OUTPUT ANTI-ALIASING FILTERS

The serial output of OTTO will be directly connected to a single CD-style 16-bit serial linear delta-sigma stereo D/A converter. Currently, the Philips TDA1545A is used. This is a low-cost, medium-performance "continuous calibration" D/A. The analog current outputs from this converter are directly connected to current-to-voltage converters and 4-pole analog low-pass active anti-aliasing filters. The current-to-voltage converters and filters are implemented using low-cost, low-noise operational amplifiers and 10%-stable (Z5U or C0G) ceramic capacitors. The outputs of the anti-aliasing filters connect directly to an input channel of the audio mixer.

4.3 - AUDIO MIXER

The audio mixer section provides mixing and level control of signals originating from the synthesizer, PCM playback, internal (CD) audio, external line-level source, and the FM synthesizer. Level control for the internal and external line sources is achieved by use of the National Semiconductor LMC835 7-band stereo graphics equalizer IC used in a unique mixer mode which provides effectively two separate 5-in stereo mixers. In this configuration, one mixer is used for controlling the line output mix, while the other provides the record mix. A control range of approximately 34dB is provided.

The mixer summing amplifier is an NE5532, gain-scaled to provide a maximum output of approximately 4V p-p, with sufficient output capability to drive high-impedance Walkman-style headphones to reasonable listening levels.

4.4 - A/D CONVERTER AND INPUT ANTI-ALIASING FILTERS

The A/D converter section is implemented using the Sony CXD2555Q CoDec, which provides a 16-bit Delta-Sigma A/D with digital filters. The input source is a record mixer described above. The microphone inputs are buffered by single-stage operational amplifier preamplifiers with approximately 20dB of gain to bring the microphone signal up to line level. For monaural sampling, the left and right channels of the record mixer can be summed. ODIE also supports monaural recording from either the left or right channel individually.

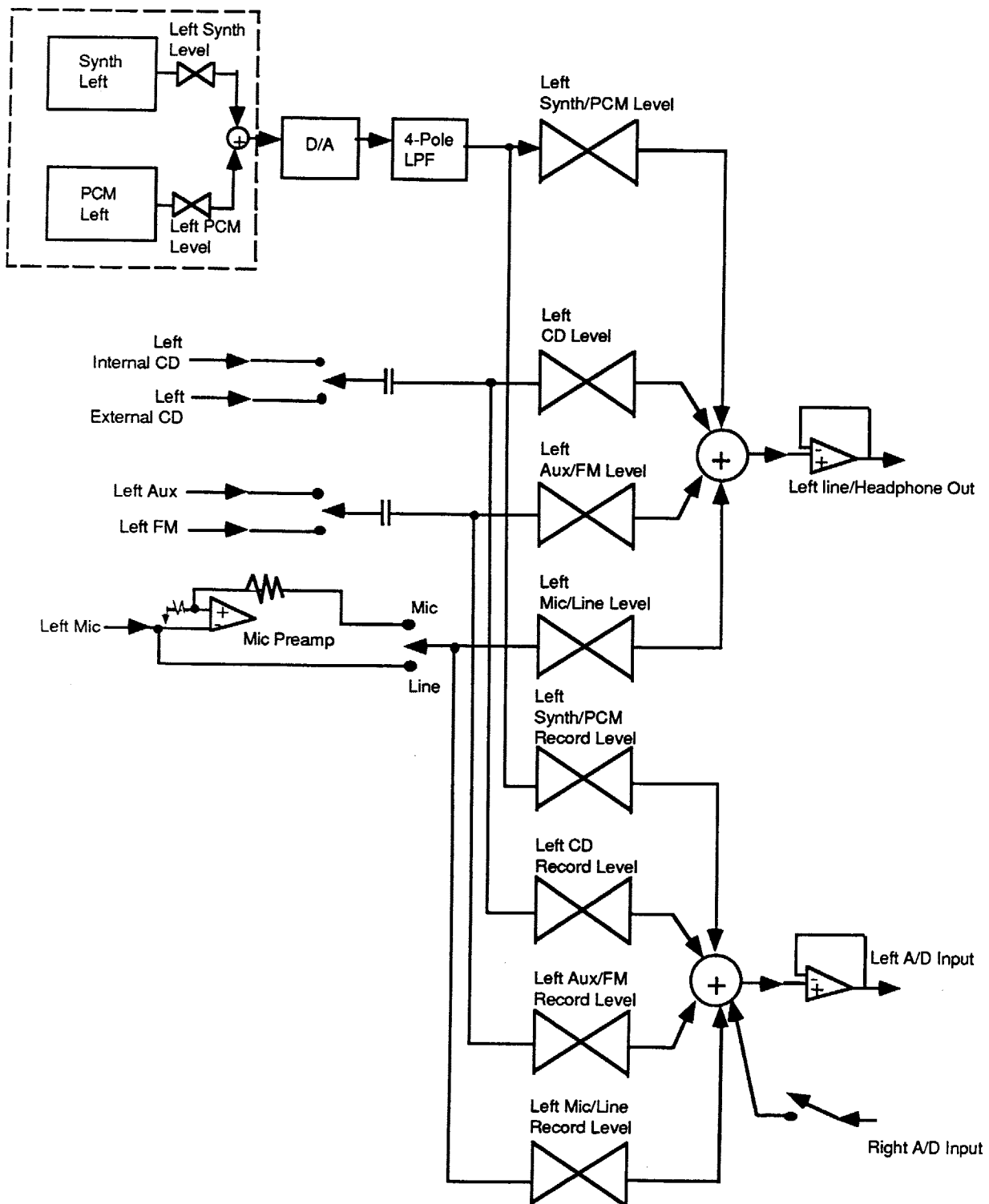

Figure 3 - Analog Section Block Diagram (Left Channel)

SECTION 5 - REGISTER AND PINOUT MAP

DIRECT-MAPPED HOST I/O REGISTERS:

MIDI INTERFACE EMULATION CONTROL/STATUS REGISTER:

ADDRESS: **BASE+0H**

IN MC6850 EMULATION MODE:

ON WRITE:

Bits 0-1	11b => Reset
Bit 2	0 => HOST Mode 1 => MIDI Mode
Bits 3-4	Ignored
Bits 5-6	01b => TxRDY Interrupt Enabled
Bit 7	1 => RxRDY Interrupt Enabled

ON READ:

Bit 0	1 => RxRDY, Forced To 0 When Reset
Bit 1	1 => TxRDY, Forced To 0 When Reset
Bit 2	0 => MIDI Mode 1 => HOST Mode
Bits 3-6	Always 0
Bit 7	1 => Interrupt Pending, Forced To 0 When Reset

IN MPU-401 EMULATION MODE:

READ/WRITE:

Bits 0-7	MPU-401 Emulation Data
----------	------------------------

Both the MIDI Emulation and HOST ports may be operated in either MC6850 emulation or MPU-401 emulation modes. The power-up default is MC6850 mode. The operating mode is controlled by the OBP. When in MPU-401 emulation mode, RxRDY interrupts are ALWAYS enabled. For maximum compatibility when operating in MPU-401 emulation mode, the Host Interrupt Configuration register should be programmed to provide a separate interrupt for the MIDI Emulation, otherwise all other interrupts can be blocked by ill-behaved applications software. Because of this, MPU-401 mode may not be generally usable on the HOST interface, but is provided there purely for the sake of symmetry.

MIDI INTERFACE EMULATION DATA REGISTER:

ADDRESS: **BASE+1H**

READ/WRITE:

Bits 0-7	MIDI Emulation Data
----------	---------------------

IN MPU-401 EMULATION MODE:

ON WRITE:

Bits 0-7	MPU-401 Emulation Command
----------	---------------------------

ON READ:

Bits 0-5	Always 1
Bit 6	0 => TxRDY
Bit 7	0 => RxRDY

HOST INTERFACE CONTROL/STATUS REGISTER:

IN MC6850 EMULATION MODE:

ADDRESS: BASE+2H

ON WRITE:

Bits 0-1	11b => Reset
Bit 2	0 => HOST Mode 1 => MIDI Mode
Bits 3-4	Ignored
Bits 5-6	01b => TxRDY Interrupt Enabled
Bit 7	1 => RxRDY Interrupt Enabled

ON READ:

Bit 0	1 => RxRDY, Forced To 0 When Reset
Bit 1	1 => TxRDY, Forced To 0 When Reset
Bit 2	0 => MIDI Mode 1 => HOST Mode
Bits 3-6	Always 0
Bit 7	1 => Interrupt Pending, Forced To 0 When Reset

IN MPU-401 EMULATION MODE:

READ/WRITE:

Bits 0-7	MPU-401 Emulation Data
----------	------------------------

HOST INTERFACE DATA REGISTER:

ADDRESS: BASE+3H

READ/WRITE:

Bits 0-7	HOST Interface Data
----------	---------------------

IN MPU-401 EMULATION MODE:

ON WRITE:

Bits 0-7	MPU-401 Emulation Command
----------	---------------------------

ON READ:

Bits 0-5	Always 1
Bit 6	0 => TxRDY
Bit 7	0 => RxRDY

ODIE INTERNAL ADDRESS REGISTER:

ADDRESS: BASE+4H

READ/WRITE:

Bits 0-3	ODIE Internal Register Address
Bits 4-7	On Write: Ignored On Read: Always 0

ODIE INTERNAL DATA REGISTER:

ADDRESS: BASE+5H

READ/WRITE:

Bits 0-7	ODIE Internal Register Data
----------	-----------------------------

NOTE - The following registers are only present when one of the SoundBlaster emulation modes is enabled in the Host Master Control Register.

SOUNDBLASTER PCM EMULATION RESET REGISTER:

ADDRESS: 226H

WRITE ONLY:

Bit 0	0 => Normal Operation 1 => Reset SoundBlaster DSP
Bits 1-7	Ignored

SOUNDBLASTER YM-3812 EMULATION ADDRESS/STATUS REGISTER:

ADDRESS: 228/388H

ON WRITE:

Bits 0-7	YM-3812 Register Address
----------	--------------------------

ON READ:

Bits 0-7	Last Data Written To Indirect Register 0CH
----------	--

SOUNDBLASTER YM-3812 EMULATION DATA REGISTER:

ADDRESS: 229/389H

WRITE ONLY:

Bits 0-7	YM-3812 Register Data
----------	-----------------------

When YM-3812 emulation is enabled in the Host Master Control Register, writing to this register will cause an immediate Non-Maskable Interrupt to the Host PC. This interrupt can be cleared either by disabling the emulation, or by writing to the write-only YM-3812 Emulation Status Register (Indirect Register 0CH).

SOUNDBLASTER PCM EMULATION RECEIVED DATA REGISTER:

ADDRESS: 22AH

READ ONLY:

Bits 0-7	SoundBlaster PCM Emulation Received Data
----------	--

SOUNDBLASTER PCM EMULATION COMMAND/TxRDY STATUS REGISTER:

ADDRESS: 22CH

ON WRITE:

Bits 0-7	SoundBlaster DSP Command/Data
----------	-------------------------------

ON READ:

Bits 0-6	Always 1
Bit 7	0 => TxRDY

SOUNDBLASTER PCM EMULATION RxRDY STATUS REGISTER:

ADDRESS: 22EH

READ ONLY:

Bits 0-6	Always 1
Bit 7	1 => RxRDY

Reading this register also clears any pending SoundBlaster interrupts.

INDIRECT-MAPPED HOST I/O REGISTERS

Ensoniq 29012E Specification

HOST INTERRUPT STATUS REGISTER (HIS):

ADDRESS: 0H

READ ONLY:

Bit 0	1 => MIDI Emulation Interrupt Pending
Bit 1	1 => HOST Interface Interrupt Pending
Bits 2-3	Always 0
Bit 4	1 => DMA A Terminal Count Interrupt Pending
Bit 5	1 => DMA B Terminal Count Interrupt Pending
Bit 6	1 => MIDI Clock Interrupt Pending
Bit 7	1 => IRQ Pending

IRQ Pending (Bit 7) is a logical OR of Bits 0-6. Bits 4-6 are cleared by toggling their respective enables to 0 in the Host Interrupt Enable Register.

ADDRESS: 1H

HOST INTERRUPT ENABLE REGISTER (HIE):

READ/WRITE:

Bits 0-3	On Write: Ignored On Read: Always 0
Bit 4	1 => DMA A Terminal Count Interrupt Enabled
Bit 5	1 => DMA B Terminal Count Interrupt Enabled
Bit 6	1 => MIDI Clock Interrupt Enabled
Bit 7	1 => Master Interrupt Enabled

When operating in Edge-Triggered Interrupt Mode, any write to this register will re-arm the interrupt controller. The DMA and MIDI Clock interrupts are cleared by toggling the respective enable bit to 0.

ADDRESS: 2H

HOST DMA A TRIGGER/STATUS REGISTER (HDAT):

READ/WRITE:

Bit 0	On Write: 1 => DMA A Trigger On Read: 1 => DMA Done
Bit 1	On Write: Ignored On Read: 1 => A/D Overflow
Bit 2	On Write: Ignored On Read: 1 => Code Download Mode Enabled
Bit 3	On Write: Ignored On Read: 1 => Host DRQ Is Asserted

Bits 4-6	DMA A Host DMA Channel Select 000b => Host DMA Channel 0 001b => Host DMA Channel 1 010b => DMA A Disabled 011b => Host DMA Channel 3 100b => DMA A Disabled 101b => Host DMA Channel 5 110b => Host DMA Channel 6 111b => Host DMA Channel 7
Bit 7	Host DMA Channel Size 0 => 16-Bit 1 => 8-Bit

DMA transfer on DMA channel A is triggered by writing a 1, then a 0 to bit 0 of this register. The DMA will actually commence on the trailing edge of the second write. Failure to follow this protocol may result in undesired or missed triggers. The DMA channel must first be initialized by the OBP. This is used during startup to trigger the DMA to perform a code download. After reset, both DMA channels are configured for 16-bit Normal In Mode, with a starting address of 000000H. It is important to initialize bit 0 to 0 while the Master Control Register is in RESET mode.

ADDRESS: 3H

HOST DMA B TRIGGER/STATUS REGISTER (HDBT):

READ/WRITE:

Bit 0	On Write: 1 => DMA Trigger On Read: 1 => DMA B Done
Bit 1	On Write: Ignored On Read: 1 => A/D Overflow
Bit 2	On Write: Ignored On Read: 1 => Code DownLoad Mode Enabled
Bit 3	On Write: Ignored On Read: 1 => Host DRQ Is Asserted
Bits 4-6	DMA B Host DMA Channel Select 000b => Host DMA Channel 0 001b => Host DMA Channel 1 010b => DMA B Disabled 011b => Host DMA Channel 3 100b => DMA B Disabled 101b => Host DMA Channel 5 110b => Host DMA Channel 6 111b => Host DMA Channel 7
Bit 7	Host DMA Channel Size 0 => 16-Bit 1 => 8-Bit

For detailed description of this register, refer to description of DMA A Trigger/Status Register above.

HOST INTERRUPT INTERFACE CONFIGURATION REGISTER (HIC):

ADDRESS: 4H

READ/WRITE:

Bits 0-1	MIDI Emulation IRQ Select 00b => IRQ0 01b => IRQ1 10b => IRQ2 11b => IRQ3
Bits 2-3	Host IRQ Select 00b => IRQ0 01b => IRQ1 10b => IRQ2 11b => IRQ3
Bits 4-5	Host/MIDI Emulation Interrupt Mode Select 00b => Edge Sensitive (Sharable) 01b => Low Level Sensitive (Sharable) 10b => Low Level Sensitive (Non-Sharable) 11b => High Level Sensitive (Non-Sharable)
Bit 6-7	CD-ROM Interface Interrupt Mode Select 00b => Edge Sensitive (Sharable) 01b => Low Level Sensitive (Sharable) 10b => Low Level Sensitive (Non-Sharable) 11b => High Level Sensitive (Non-Sharable)

Four different host interrupt interfaces are provided. In Edge Sensitive mode, when an interrupt occurs, a low pulse will be asserted on the selected host IRQ line. The IRQ lines are driven by tri-state drivers which are enabled only when outputting the pulse. In this way, multiple boards may share the same IRQ line. When operating in this mode, it is essential that each interrupt handler perform a write to the Host Interrupt Enable register AFTER issuing an EOI to the host machines interrupt controller. This will cause the interrupt interface to generate another low pulse on the IRQ line if additional interrupts are still pending.

In the Sharable Low Level Sensitive mode, the selected IRQ line is again driven by a tri-state driver, which is enabled only when an interrupt is pending. The selected IRQ line is held low until all pending interrupts are cleared. Since the drivers are enabled only to drive the IRQ line LOW, multiple boards may share the same IRQ line.

The Non-Sharable Low Level Sensitive and Non-Sharable High Level Sensitive modes ALWAYS drive the selected IRQ line, regardless of whether there are pending interrupts. Because of this, only a single board may use a given IRQ line at any one time. This mode, is, however, compatible with the interrupt architecture of most ISA-bus add-in cards, and PC- and

XT-class machines.

HOST DMA INTERFACE CONFIGURATION REGISTER (HDC):

ADDRESS: 5H

READ/WRITE:

Bits 0-3	On Write: Ignored On Read: Always 0
Bit 4	DMA A & B DRQ Polarity 0 => Active LOW 1 => Active HIGH
Bit 5	DMA A & B DACK Polarity 0 => Active LOW 1 => Active HIGH
Bit 6	CD-ROM DMA DRQ Polarity 0 => INVERTED 1 => TRUE
Bit 7	CD-ROM DMA DACK Polarity 0 => TRUE 1 => INVERTED

HOST CD-ROM/SCSI INTERFACE CONFIGURATION REGISTER (HCDC):

ADDRESS: 6H

READ/WRITE:

Bit 0	CD-ROM Interrupt Enable 0 => Disabled 1 => Enabled
Bits 1-2	CD-ROM IRQ Select 00b => IRQ0 01b => IRQ1 10b => IRQ2 11b => IRQ3
Bit 3	CD-ROM DMA Enable 0 => Disabled 1 => Enabled

Bits 4-6	CD-ROM DMA Channel Select 000b => Host DMA Channel 0 001b => Host DMA Channel 1 010b => CD-ROM DMA Disabled 011b => Host DMA Channel 3 100b => CD-ROM DMA Disabled 101b => Host DMA Channel 5 110b => Host DMA Channel 6 111b => Host DMA Channel 7
Bit 7	CD-ROM Interface Enable 0 => Disabled 1 => Enabled

Note that to minimize interaction between the S-1000 and the CD-ROM, this register is not affected by subsystem resets. Only a hardware (power-up) reset will clear this register.

SOUND MEMORY CONFIGURATION REGISTER A (HMCA):

ADDRESS: 7H

READ/WRITE:

Bit 0	Device 0 Memory Type 0 => DRAM 1 => ROM/SRAM
Bit 1	Device 1 Memory Type 0 => DRAM 1 => ROM/SRAM
Bit 2	Device 2 Memory Type 0 => DRAM 1 => ROM/SRAM
Bit 3	Device 3 Memory Type 0 => DRAM 1 => ROM/SRAM
Bits 4-6	Sound Memory Device Size Select 000b => 8Mw 001b => 4Mw 010b => 2Mw 011b => 1Mw 100b => 512Kw 101b => 256Kw 110b => 128Kw 111b => 64Kw
Bit 7	CAS4 Function Select 0 => CAS4 = CAS1+CAS2 1 => CAS4 = CAS0+CAS1

SOUND MEMORY CONFIGURATION REGISTER B (HMCB):

ADDRESS: 8H

READ/WRITE:

Bits 0-1	DRAM 0 Size 00b => 64K 01b => 256K 10b => 1M 11b => 4M
Bits 2-3	DRAM 1 Size 00b => 64K 01b => 256K 10b => 1M 11b => 4M
Bits 4-5	DRAM 2 Size 00b => 64K 01b => 256K 10b => 1M 11b => 4M
Bits 6-7	DRAM 3 Size 00b => 64K 01b => 256K 10b => 1M 11b => 4M

HOST MASTER CONTROL REGISTER (HMC):

ADDRESS: 9H

READ/WRITE:

Bits 0-1	SoundBlaster Emulation Mode Select: 00b => SoundBlaster Emulation Disabled 01b => SoundBlaster + OPL-2 Enabled 10b => SoundBlaster + OPL-3 Enabled 11b => SoundBlaster + OPL-2 Emulation Enabled
Bit 2	AdLib Yamaha FM Address: 0 => OPL-2/Emulation Disabled At 388-389H 1 => OPL-2/Emulation Enabled At 388-389H
Bit 3	0 => Joystick Interface Disabled 1 => JoyStick Interface Enabled
Bits 4-5	00b => CD-ROM At Base + 6 thru Base + 7 01b => CD-ROM At Base + 8 thru Base + 15 10b => CD-ROM At Base + 16 thru Base + 31 11b => CD-ROM At Base + 16 thru Base + 47

Bits 6-7	Subsystem Master Control Bits 00b => Subsystem Hardware Reset 01b => Normal Operation OBP Enabled, DMA Disabled, Refresh Disabled 10b => Code Download Mode OBP Suspended, DMA Enabled, Refresh Enabled 11b => OBP Startup Mode OBP Enabled, DMA Disabled, Refresh Enabled
----------	---

YM-3812 EMULATION ADDRESS REGISTER (HFMA):

ADDRESS: AH

READ ONLY:

Bits 0-7	Last Data Written To Host Port 228H
----------	-------------------------------------

YM-3812 EMULATION DATA REGISTER (HFMD):

ADDRESS: BH

READ ONLY:

Bits 0-7	Last Data Written To Host Port 229H
----------	-------------------------------------

YM-3812 EMULATION STATUS REGISTER (HFMS):

ADDRESS: CH

WRITE ONLY:

Bits 0-7	YM-3812 Emulation Status
----------	--------------------------

Any write to this register will clear a pending NMI.

DIRECT-MAPPED ON-BOARD PROCESSOR REGISTERS: MIDI INTERFACE EMULATION CONTROL/STATUS REGISTER:

ADDRESS: A00000H

READ/WRITE:

Bit 0	On Write: Ignored On Read: 1 => RxRDY, Forced To 0 When Reset
Bit 1	On Write: Ignored On Read: 1 => TxRDY, Forced To 0 When Reset
Bit 2	0 => Data Register Contains MIDI/Data Byte 1 => Data Register Contains HOST/Command Byte
Bit 3	0 => MIDI Mode 1 => HOST Mode

Bit 4	0 => MC6850 Mode 1 => MPU-401 Mode
Bit 5	On Write: Ignored On Read: HOST Reset Status: 0 => Reset 1 => Normal Operation
Bit 6	1 => TxRDY Interrupt Enabled
Bit 7	1 => RxRDY Interrupt Enabled

The interface is reset by writing 11b to bits 3 and 4.

MIDI INTERFACE EMULATION DATA REGISTER:

ADDRESS: A00001H

READ/WRITE:

Bits 0-7	MIDI Emulation Data
----------	---------------------

HOST INTERFACE CONTROL/STATUS REGISTER:

ADDRESS: A00002H

READ/WRITE:

Bit 0	On Write: Ignored On Read: 1 => RxRDY, Forced To 0 When Reset
Bit 1	On Write: Ignored On Read: 1 => TxRDY, Forced To 0 When Reset
Bit 2	0 => Data Register Contains MIDI/Data Byte 1 => Data Register Contains HOST/Command Byte
Bit 3	0 => MIDI Mode 1 => HOST Mode
Bit 4	0 => MC6850 Mode 1 => MPU-401 Mode
Bit 5	HOST Reset Status: 0 => Reset 1 => Normal Operation
Bit 6	1 => TxRDY Interrupt Enabled
Bit 7	1 => RxRDY Interrupt Enabled

The interface is reset by writing 11b to bits 3 and 4.

HOST INTERFACE DATA REGISTER:

ADDRESS: A00003H

READ/WRITE:

Bits 0-7	HOST Interface Data
----------	---------------------

MIDI INTERFACE CONTROL/STATUS REGISTER:

ADDRESS: A00004H

READ/WRITE:

Bit 0	1 => RxRDY
Bit 1	1 => TxRDY
Bit 2	On Write: Ignored On Read: Always 0
Bits 3-4	11b => Reset
Bit 5	On Write: Ignored On Read: Reset Status 0 => Reset 1 => Normal Operation
Bit 6	1 => TxRDY Interrupt Enabled
Bit 7	1 => RxRDY Interrupt Enabled

MIDI INTERFACE DATA REGISTER:

ADDRESS: A00005H

READ/WRITE:

Bits 0-7	MIDI Data
----------	-----------

INTERRUPT CONTROL REGISTER:

ADDRESS: A00006H

READ/WRITE:

Bits 0-2	On Write: Ignored On Read: Always 0
Bit 3	1 => OTTO Interrupt Enabled
Bit 4	1 => Timer Interrupt Enabled
Bit 5	1 => DMA A Terminal Count Interrupt Enabled
Bit 6	1 => DMA B Terminal Count Interrupt Enabled
Bit 7	1 => MIDI Clock Interrupt Enabled

INTERRUPT STATUS/YM-3812 STATUS REGISTER:

ADDRESS: A00007H

ON READ:

Bit 0	1 => MIDI Interface Interrupt Pending
Bit 1	1 => OTTO Interrupt Pending
Bit 2	1 => Host Interface Interrupt Pending
Bit 3	1 => MIDI Emulation Interface Interrupt Pending
Bit 4	1 => Timer Interrupt Pending
Bit 5	1 => DMA A Complete Interrupt Pending
Bit 6	1 => DMA B Complete Interrupt Pending
Bit 7	1 => MIDI Clock/SoundBlaster Interrupt Pending

ON WRITE:

Bits 0-7	YM-3812 Emulation Status
----------	--------------------------

On read, this register gives the current status of all interrupt sources. The Timer, DMA, and MIDI Clock interrupts are cleared by toggling their respective enable bits LOW. The SoundBlaster interrupt is cleared by writing the SoundBlaster control register. The DMA complete interrupts will occur on one of two conditions depending on DMA mode. For normal (sample data) transfers these interrupts will occur on Terminal Count. For PCM and A/D transfers, these interrupts will occur at the end of each buffer transfer (2K samples). On write, data is written to the Host YM-3812 Emulation Status Register. Note that there is NO arbitration, so this register must not be simultaneously written by the OBP and the HOST, or results will be unpredictable.

DMA A CONTROL REGISTER:

ADDRESS: A00008H

READ/WRITE:

Bits 0-1	DMA Mode 00b => Disabled (Reset) 01b => Normal Mode 10b => PCM Playback Mode 11b => A/D Record Mode
Bit 2	In Modes 0-2: DMA Direction 0 => DMA In (From Host) 1 => DMA Out (To Host) In Mode 3: A/D Data Format 0 => I2S Format (Left Justified) 1 => Japanese Format (Right Justified)

Bit 3	Data Type 0 => Non-Interleaved/Mono 1 => Interleaved Stereo
Bits 4-5	Data Size 00b => 16-Bit Linear 01b => 12-Bit Linear 10b => 8-Bit Linear 11b => μ -Law Compressed
Bit 6	Data Format 0 => Signed 1 => Unsigned
Bit 7	DMA Halt 0 => DMA Transfer Enabled 1 => DMA Transfer Halted

The DMA Mode bits, when both 0, places the DMA hardware in a RESET state, immediately stopping any transfer in process. To perform a DMA transfer, the DMA Control Register should first be initialized, then perform a write to the DMA Trigger register to begin the transfer of data. To terminate a transfer before reaching Terminal Count (or other normal termination criteria), the DMA Control register should be written again with the DMA Halt bit SET. Any single sample transfer currently in progress will be completed, and then the DMA hardware will return to an idle state. Note that when a transfer is stopped using the HALT bit, the transfer will actually halt after the next sample, if MONO mode, or after the next pair of samples if STEREO mode. After being HALT'ed, a transfer can be restarted from where it left off by again writing to the DMA Trigger register, or the DMA Address Registers can be read to determine the exact number of samples remaining in the buffer. Note that in the case of A/D transfers, both DMA channels are used. One will be set to A/D mode, to read data from the A/D converter into memory, the other will be set to PCM mode, to transfer the data from memory to the host. In this mode, the trigger for the PCM channel is provided automatically by the A/D channel, so it is important that the A/D channel be stopped first, to prevent the PCM channel from being re-triggered after it is stopped. Issuing a trigger to a DMA channel that is not stopped may result in anomolous behavior.

DMA A TRIGGER/STATUS REGISTER:

ADDRESS: A00009H

ON WRITE:

Bits 0-7	Ignored: Any Write Triggers DMA
----------	---------------------------------

ON READ:

Bit 0	1 => DMA Done
Bit 1	1 => A/D Overflow
Bit 2	1 => Code Download Mode Enabled
Bit 3	1 => Host DMA Channel Is 8-Bit
Bit 4	1 => Host DRQ Is Asserted

Bit 5	1 => Memory Request Is Asserted
Bit 6	1 => Left Channel A/D Request Is Asserted
Bit 7	1 => Right Channel A/D Request Is Asserted

DMA A ADDRESS REGISTERS:

ADDRESS: A0000A-BH WORD ADDRESSABLE ONLY

READ/WRITE:

Bits 0-6	DMA A Buffer Address Bits 16-22
Bit 7	On Write: Ignored On Read: Always 0
Bits 8-15	On Write: Ignored On Read: Current YM3812 Emulation Address

ADDRESS: A0000C-DH WORD ADDRESSABLE ONLY

READ/WRITE:

Bits 0-15	DMA A Buffer Address Bits 0-15
-----------	--------------------------------

DMA B CONTROL REGISTER:

ADDRESS: A0000EH

READ/WRITE:

Bits 0-1	DMA Mode 00b => Disabled (Reset) 01b => Normal Mode 10b => PCM Playback Mode 11b => A/D Record Mode
Bit 2	In Modes 0-2: DMA Direction 0 => DMA In (From Host) 1 => DMA Out (To Host) In Mode 3: A/D Data Format 0 => I2S Format (Left Justified) 1 => Japanese Format (Right Justified)
Bit 3	Data Type 0 => Non-Interleaved/Mono 1 => Interleaved Stereo
Bits 4-5	Data Size 00b => 16-Bit Linear 01b => 12-Bit Linear 10b => 8-Bit Linear 11b => μ -Law Compressed

Bit 6	Data Format 0 => Signed 1 => Unsigned
Bit 7	DMA Halt 0 => DMA Transfer Enabled 1 => DMA Transfer Halted

For operational details, see the DMA A Control register description above.

DMA B TRIGGER/STATUS REGISTER:

ADDRESS: A0000FH

ON WRITE:

Bits 0-7	Ignored: Any Write Triggers DMA
----------	---------------------------------

ON READ:

Bit 0	1 => DMA Done
Bit 1	1 => A/D Overflow
Bit 2	Unused, Always 0
Bit 3	1 => Host DMA Channel Is 8-Bit
Bit 4	1 => Host DMA Request Is Asserted
Bit 5	1 => Memory Request Is Asserted
Bit 6	1 => Left Channel A/D Request Is Asserted
Bit 7	1 => Right Channel A/D Request Is Asserted

DMA B ADDRESS REGISTERS:

ADDRESS: A00010-11H WORD ADDRESSABLE ONLY

READ/WRITE:

Bits 0-6	DMA B Buffer Address Bits 16-22
Bit 7	On Write: Ignored On Read: Always 0
Bits 8-15	On Write: Ignored On Read: Current YM3812 Emulation Data

ADDRESS: A00012-13H WORD ADDRESSABLE ONLY

READ/WRITE:

Bits 0-15	DMA B Buffer Address Bits 0-15
-----------	--------------------------------

MIDI CLOCK COUNT REGISTER:

ADDRESS: A00014-15H WORD ADDRESSABLE ONLY

READ/WRITE:

Bits 0-11	MIDI Clock Count Bits 0-11
Bits 12-15	On Write: Ignored On Read: Always 0

PWM COUNT REGISTERS:

ADDRESS: A00016H

READ/WRITE:

Bit 0	0 => Digital Out Mode 1 => PWM Mode
Bits 1-7	PWM0 Duty Cycle

When Bit 0 is 0, Bit 1 is connected directly to the PWMA pin. When Bit 0 is 1, the PWM0 output is connected to the PWMA pin.

ADDRESS: A00017H

READ/WRITE:

Bit 0	0 => Digital Out Mode 1 => PWM Mode
Bits 1-7	PWM1 Duty Cycle

When Bit 0 is 0, Bit 1 is connected directly to the PWMB pin. When Bit 0 is 1, the PWM1 output is connected to the PWMB pin.

ADDRESS: A00018H

READ/WRITE:

Bit 0	0 => Digital Out Mode 1 => PWM Mode
Bits 1-7	PWM2 Duty Cycle

When Bit 0 is 0, Bit 6 of the OBP A/D Control Register is connected directly to the PWMC pin. When Bit 0 is 1, the PWM2 output is connected to the PWMC pin.

ADDRESS: A00019H

READ/WRITE:

Bit 0	0 => Digital Out Mode 1 => PWM Mode
-------	--

Bits 1-7	PWM3 Duty Cycle
----------	-----------------

When Bit 0 is 0, Bit 7 of the OBP A/D Control Register is connected directly to the PWMD pin. When Bit 0 is 1, the PWM3 output is connected to the PWMD pin.

A/D CONTROL REGISTER:

ADDRESS: A0001AH

READ/WRITE:

Bits 0-7	A/D Control Bits (ADCTL0-7)
----------	-----------------------------

Bits 0-5 are output on the dedicated ACTL0-5 pins, while bits 6 & 7 are output on the PWMC & PWMD output pins. See the descriptions of the PWM count registers for details of how these outputs are configured and controlled.

MISCELLANEOUS CONTROL REGISTER:

ADDRESS: A0001BH

READ/WRITE:

Bits 0-1	OBP Sound Memory Bank Select 00b => Bank 0 00b => Bank 1 10b => Bank 2 11b => Bank 3
Bits 2-3	OBP F-Page Memory CAS/CS Select 00b => CAS0*/CS0* 00b => CAS1*/CS1* 10b => CAS2*/CS2* 11b => CAS3*/CS3*
Bits 4-5	Timer Interrupt Rate Select 00b => 1 mSec 01b => 2 mSec 10b => 4 mSec 11b => 8 mSec
Bit 6	1 => OTTO PCM Playback Mode Enabled
Bit 7	1 => Code Download/ Auto Refresh Mode Disabled

OBP MISCELLANEOUS STATUS REGISTER:

ADDRESS: A0001CH

READ ONLY:

Bit 0	Device 0 Memory Type 0 => DRAM 1 => ROM/SRAM
-------	--

Bit 1	Device 1 Memory Type 0 => DRAM 1 => ROM/SRAM
Bit 2	Device 2 Memory Type 0 => DRAM 1 => ROM/SRAM
Bit 3	Device 3 Memory Type 0 => DRAM 1 => ROM/SRAM
Bits 4-6	Sound Memory Device Size Select 000b => 8Mw 001b => 4Mw 010b => 2Mw 011b => 1Mw 100b => 512Kw 101b => 256Kw 110b => 128Kw 111b => 64Kw
Bit 7	Always 0

TEST MODE CONTROL/STATUS REGISTER:

ADDRESS: A0001DH

READ/WRITE:

Bit 0	1 => UART Loopback Mode Enabled
Bit 1	1 => DMA Address Counter Test Mode Enabled
Bit 2	1 => A/D Interface Test Mode Enabled
Bit 3	1 => Timer Turbo Mode Enabled
Bit 4	1 => Edge-Triggered Interrupt Test Mode Enabled
Bit 5	1 => DMA A A/D Interface Test Output Enabled
Bit 6	1 => DMA B A/D Interface Test Output Enabled
Bit 7	1 => A/D DMA Trigger Disabled

SOUNDBLASTER PCM CONTROL/STATUS REGISTER:

ADDRESS: A0001EH

READ/WRITE:

Bit 0	1 => RxRDY
Bit 1	1 => TxRDY
Bit 2	On Write: Ignored On Read: HOST Reset Register Writtten Flag 1 => Reset Register Written
Bit 3	0 => HOST Interface Is Polled 1 => HOST Interface Is Interrupt-Driven

Bit 4	On Write: 0->1 Transition Generates Interrupt To Host On Read: Always 0
Bit 5	On Write: Ignored On Read: HOST Reset Status 0 => Normal Operation 1 => Reset
Bit 6	1 => TxRDY Interrupt Enabled
Bit 7	1 => RxRDY Interrupt Enabled

The OBP will be interrupted any time the HOST SoundBlaster PCM Emulation Reset Register is written. Bit 2 of this register will be set to indicate that a HOST Reset was the source of a pending interrupt. Bit 2 will remain set until this register is again written. Bit 5 indicates the current state of the HOST Reset bit. HOST Reset interrupts are cleared by clearing the RxRDY Interrupt Enable (Bit 7). RxRDY/TxRDY interrupts are automatically cleared by reading/writing the SoundBlaster PCM Data Register.

SOUNDBLASTER PCM DATA REGISTER:

ADDRESS: A0001FH

READ/WRITE:

Bits 0-7	SoundBlaster Emulation Command/Data
----------	-------------------------------------

PIN ASSIGNMENTS: PIN# EXT. NAME INT. NAME TYPE DESCRIPTION

PIN#	EXT. NAME	INT. NAME	TYPE	DESCRIPTION
1	GND	PWR		
2	GND	PWR		
3	HD0	DH0	I/O	Host PC Data Bit 0
4	HD1	DH1	I/O	Host PC Data Bit 1
5	HD2	DH2	I/O	Host PC Data Bit 2
6	HD3	DH3	I/O	Host PC Data Bit 3
7	HD4	DH4	I/O	Host PC Data Bit 4
8	HD5	DH5	I/O	Host PC Data Bit 5
9	HD6	DH6	I/O	Host PC Data Bit 6
10	HRST	MRST	IN	
11	HD7	DH7	I/O	Host PC Data Bit 7
12	HDLE*	DLEH	OUT	Host PC Data Bus Lower Byte Enable
13	BASE0	BAS0	IN	Base Address Select 0
14	BASE1	BAS1	IN	Base Address Select 1

15	YCS*/NMI	CSYM	OUT	Yamaha Chip Select/NMI
16	JSRD*	RDJS	OUT	Joystick Read
17	JSWR*	WRJS	OUT	Joystick Write
18	PWM0	PWM0	OUT	Pulse Width Modulator 0
19	PWM1	PWM1	OUT	Pulse Width Modulator 1
20	PWM2	PWM2	OUT	Pulse Width Modulator 2
21	PWM3	PWM3	OUT	Pulse Width Modulator 3
22	ACTL0	AC0	OUT	Analog Control Bit 0
23	ACTL1	AC1	OUT	Analog Control Bit 1
24	ACTL2	AC2	OUT	Analog Control Bit 2
25	ACTL3	AC3	OUT	Analog Control Bit 3
26	GND		PWR	
27	VCC		PWR	
28	ACTL4	AC4	OUT	Analog Control Bit 4
29	ACTL5	AC5	OUT	Analog Control Bit 5
30	ADDATA	ADD	I/O	A/D Converter Serial Data
31	ADBCLK	ABC	I/O	A/D Converter Bit Clock
32	ADLRCLK	ALR	I/O	A/D Converter L/R Clock
33	RXD	MRXD	IN	MIDI Receive Data
34	TXD	MTXD	OUT	MIDI Transmit Data
35	OSCI	OSCI	IN	32 MHz Oscillator Buffer In
36	OSCO	OSCO	OUT	32 MHz Oscillator Buffer Out
37	PCLK	CLKP	OUT	Processor Clock
38	DTACK*	ACKP	O/D	Processor Data Transfer Acknowledge
39	PRW	RWP	IN	Processor R/W
40	PLDS*	LDSP	IN	Processor Lower Data Strobe
41	PUDS*	UDSP	IN	Processor Upper Data Strobe
42	PAS*	ASP	IN	Processor Address Strobe
43	PD0	DP0	I/O	Processor Data Bit 0
44	PD1	DP1	I/O	Processor Data Bit 1
45	PD2	DP2	I/O	Processor Data Bit 2
46	PD3	DP3	I/O	Processor Data Bit 3
47	PD4	DP4	I/O	Processor Data Bit 4
48	PD5	DP5	I/O	Processor Data Bit 5
49	PD6	DP6	I/O	Processor Data Bit 6
50	PD7	DP7	I/O	Processor Data Bit 7
51	GND		PWR	
52	GND		PWR	
53	VCC		PWR	
54	NC		--	
55	PD8	DP8	I/O	Processor Data Bit 8
56	PD9	DP9	I/O	Processor Data Bit 9
57	PD10	DPA	I/O	Processor Data Bit 10
58	PD11	DPB	I/O	Processor Data Bit 11

Ensoniq ODIE Specification

59	PD12	DPC	I/O	Processor Data Bit 12
60	PD13	DPD	I/O	Processor Data Bit 13
61	PD14	DPE	I/O	Processor Data Bit 14
62	PD15	DPF	I/O	Processor Data Bit 15
63	PA23	APN	IN	Processor Address Bit 23
64	PA22	APM	IN	Processor Address Bit 22
65	PA21	APL	IN	Processor Address Bit 21
66	PA20	APK	IN	Processor Address Bit 20
67	PA19	APJ	IN	Processor Address Bit 19
68	PA18	API	IN	Processor Address Bit 18
69	PA17	APH	IN	Processor Address Bit 17
70	PA16	APG	IN	Processor Address Bit 16
71	PA15	APF	IN	Processor Address Bit 15
72	PA14	APE	IN	Processor Address Bit 14
73	PA13	APD	IN	Processor Address Bit 13
74	PA12	APC	IN	Processor Address Bit 12
75	PA11	APB	IN	Processor Address Bit 11
76	PA10	APA	IN	Processor Address Bit 10
77	PA9	AP9	IN	Processor Address Bit 9
78	VCC		PWR	
79	GND		PWR	
80	PA8	AP8	IN	Processor Address Bit 8
81	PA7	AP7	IN	Processor Address Bit 7
82	PA6	AP6	IN	Processor Address Bit 6
83	PA5	AP5	IN	Processor Address Bit 5
84	PA4	AP4	IN	Processor Address Bit 4
85	PA3	AP3	IN	Processor Address Bit 3
86	PA2	AP2	IN	Processor Address Bit 2
87	PA1	AP1	IN	Processor Address Bit 1
88	FC0	FC0P	IN	Processor Function Code 0
89	FC1	FC1P	IN	Processor Function Code 1
90	IPL0*	IPL0	OUT	Processor Interrupt Priority 0
91	IPL1*	IPL1	OUT	Processor Interrupt Priority 1
92	IPL2*	IPL2	OUT	Processor Interrupt Priority 2
93	PRST*	RSTP	O/D	Processor Reset
94	PHLT*	HLTP	O/D	Processor Halt
95	DABCLK	DBC	I/O	D/A Converter Bit Clock
96	DALRCLK	DLR	I/O	D/A Converter L/R Clock
97	DADATA	DAD	I/O	D/A Converter Serial Data
98	AD15	AOK	I/O	Sound Memory Address/Data Bit 15
99	AD14	AOJ	I/O	Sound Memory Address/Data Bit 14
100	AD13	AOI	I/O	Sound Memory Address/Data Bit 13
101	AD12	AOH	I/O	Sound Memory Address/Data Bit 12
102	AD11	AOG	I/O	Sound Memory Address/Data Bit 11

103	NC		—	
104	VCC		PWR	
105	GND		PWR	
106	GND		PWR	
107	AD10	AOF	I/O	Sound Memory Address/Data Bit 10
108	AD9	AOE	I/O	Sound Memory Address/Data Bit 9
109	AD8	AOD	I/O	Sound Memory Address/Data Bit 8
110	AD7	AOC	I/O	Sound Memory Address/Data Bit 7
111	AD6	AOB	I/O	Sound Memory Address/Data Bit 6
112	AD5	AOA	I/O	Sound Memory Address/Data Bit 5
113	AD4	AO9	I/O	Sound Memory Address/Data Bit 4
114	AD3	AO8	I/O	Sound Memory Address/Data Bit 3
115	AD2	AO7	I/O	Sound Memory Address/Data Bit 2
116	AD1	AO6	I/O	Sound Memory Address/Data Bit 1
117	AD0	AO5	I/O	Sound Memory Address/Data Bit 0
118	OA4	AO4	I/O	Sound Memory Address Bit 4
119	OA3	AO3	I/O	Sound Memory Address Bit 3
120	OA2	AO2	I/O	Sound Memory Address Bit 2
121	OA1	AO1	I/O	Sound Memory Address Bit 1
122	OA0	AO0	I/O	Sound Memory Address Bit 0
123	OA22	AOM	I/O	Sound Memory Address Bit 22
124	OA21	AOL	I/O	Sound Memory Address Bit 21
125	OIRQ*	IRQO	IN	OTTO Interrupt Request
126	OCLK	CLKO	OUT	OTTO 16 MHz Master Clock
127	ECLK	CLKE	OUT	OTTO E Clock
128	OCS*	CSO	OUT	OTTO Chip Select
129	AMUX	AMUX	OUT	Address MUX Control
130	VCC		PWR	
131	GND		PWR	
132	UWEN*	UWEN	OUT	Sound Memory Upper Byte Write Enable
133	LWEN*	LWEN	OUT	Sound Memory Lower Byte Write Enable
134	RAS*	RAS	OUT	Sound Memory Row Address Strobe
135	CAS0*	CAS0	OUT	Sound Memory Column Address Strobe 0
136	CAS1*	CAS1	OUT	Sound Memory Column Address Strobe 1
137	CAS2*	CAS2	OUT	Sound Memory Column Address Strobe 2
138	CAS3*	CAS3	OUT	Sound Memory Column Address Strobe 3
139	CAS4*	CAS4	OUT	Sound Memory Column Address Strobe 4
140	XA0	XA0	OUT	Multiplexed Sound Memory Address Bit 0
141	XA1	XA1	OUT	Multiplexed Sound Memory Address Bit 1
142	XA2	XA2	OUT	Multiplexed Sound Memory Address Bit 2
143	XA3	XA3	OUT	Multiplexed Sound Memory Address Bit 3
144	XA4	XA4	OUT	Multiplexed Sound Memory Address Bit 4
145	XA5	XA5	OUT	Multiplexed Sound Memory Address Bit 5
146	XA6	XA6	OUT	Multiplexed Sound Memory Address Bit 6

147	XA7	XA7	OUT	Multiplexed Sound Memory Address Bit 7
148	XA8	XA8	OUT	Multiplexed Sound Memory Address Bit 8
149	XA9	XA9	OUT	Multiplexed Sound Memory Address Bit 9
150	XA10	XA10	OUT	Multiplexed Sound Memory Address Bit 10
151	LA5	LA5	OUT	Latched Sound Memory Address Bit 5
152	LA6	LA6	OUT	Latched Sound Memory Address Bit 6
153	LA7	LA7	OUT	Latched Sound Memory Address Bit 7
154	LA8	LA8	OUT	Latched Sound Memory Address Bit 8
155	GND		PWR	
156	GND		PWR	
157	VCC		PWR	
158	NC		--	
159	LA9	LA9	OUT	Latched Sound Memory Address Bit 9
160	CDCS*	CSCD	OUT	CD-ROM Interface Chip Select
161	CDIRQ	IRCD	IN	CD-ROM Interface Interrupt Request
162	CDDRQ	DRCD	IN	CD-ROM Interface DMA Request
163	CDDACK	ACD	OUT	CD-ROM Interface DMA Acknowledge
164	CDRST*	RSTC	OUT	CD-ROM Interface Reset
165	HD15	DHF	I/O	Host PC Data Bit 15
166	HD14	DHE	I/O	Host PC Data Bit 14
167	HD13	DHD	I/O	Host PC Data Bit 13
168	HDRQ7	RQ7	OUT	Host PC Channel 7 DMA Request
169	HD12	DHC	I/O	Host PC Data Bit 12
170	HDACK7	ACK7	IN	Host PC Channel 7 DMA Acknowledge
171	HD11	DHB	I/O	Host PC Data Bit 11
172	HDRQ6	RQ6	OUT	Host PC Channel 6 DMA Request
173	HD10	DHA	I/O	Host PC Data Bit 10
174	HDACK6	ACK6	IN	Host PC Channel 6 DMA Acknowledge
175	HD9	DH9	I/O	Host PC Data Bit 9
176	HDRQ5	RQ5	OUT	Host PC Channel 5 DMA Request
177	HD8	DH8	I/O	Host PC Data Bit 8
178	HDHE*	DHEH	OUT	Host PC Data Bus High Byte Enable
179	HDACK5	ACK5	IN	Host PC Channel 5 DMA Acknowledge
180	HDRQ0	RQ0	OUT	Host PC Channel 0 DMA Request
181	HDACK0	ACK0	IN	Host PC Channel 0 DMA Acknowledge
182	GND		PWR	
183	VCC		PWR	
184	HBHE*	BHEH	IN	Host PC Bus High Enable
185	HIRQ3	IH3	I/O	Host PC Interrupt Request 3
186	HIRQ2	IH2	I/O	Host PC Interrupt Request 2
187	HIRQ1	IH1	I/O	Host PC Interrupt Request 1
188	HIRQ0	IH0	I/O	Host PC Interrupt Request 0
189	HA0	AH0	IN	Host PC Address Bit 0
190	HA1	AH1	IN	Host PC Address Bit 1

191	HA2	AH2	IN	Host PC Address Bit 2
192	HA3	AH3	IN	Host PC Address Bit 3
193	HTC	TCH	IN	Host PC DMA Terminal Count
194	HA4	AH4	IN	Host PC Address Bit 4
195	HA5	AH5	IN	Host PC Address Bit 5
196	HA6	AH6	IN	Host PC Address Bit 6
197	HA7	AH7	IN	Host PC Address Bit 7
198	HA8	AH8	IN	Host PC Address Bit 8
199	HA9	AH9	IN	Host PC Address Bit 9
200	HDRQ1	RQ1	OUT	Host PC Channel 1 DMA Request
201	HDACK1	ACK1	IN	Host PC Channel 1 DMA Acknowledge
202	HDRQ3	RQ3	OUT	Host PC Channel 3 DMA Request
203	HDACK3	ACK3	IN	Host PC Channel 3 DMA Acknowledge
204	HIOR*	IORH	IN	Host PC I/O Read
205	HLOW*	IOWH	IN	Host PC I/O Write
206	HAEN*	AENH	IN	Host PC Address Enable
207	NC		---	
208	VCC		PWR	

ENSONIQ Multimedia Products - International Distributors

Territory	Distributor	(P) Phone (F) FAX
Canada	Valtrie Marketing Inc. 226 Galaxy Boulevard Rexdale, Ontario Canada M9W 5R8	(P) 416-798-2555 (F) 416-798-2560
Hong Kong	Wong's Kong King (Holdings) Ltd. WKK Building, 418A Kwun Tong Road Kwun Tong, Kowloon Hong Kong	(P) 011-852-345-0121 (F) 011-852-341-9339
Korea	Components Agent Korea, Ltd. #1501 Samkoo Building, 16-49, Hangangro 3-Ka, Yong San-Ku Seoul, Korea	(P) 011-82-2-705-0707 (F) 011-82-2-705-0725
Singapore	Technology Distribution(s) PTE Ltd. No. 1 Syed Alwi Road Song Lin Building (#05-02) Singapore 0820	(P) 011-65-299-7811 (F) 011-65-294-1518
United Kingdom	Thame Components Ltd. Thame Park Road Thame, Oxfordshire, England OX9 3UQ	(P) 011-44-8-44-261188 (F) 011-44-8-44-261681

International Manufacturer's Rep

United Kingdom	Magna Technology Wyvols Court Old Basingstoke Road Swallowfield, Berkshire, England RG7 1PY	(P) 011-44-734-880211 (F) 011-44-734-882116
----------------	--	--

North American Manufacturer's Reps

Long Island, New Jersey	ERA 354 Veteran's Memorial Hwy. Commack, NY 11725	(P) 516-543-0510 (F) 516-543-0758
Delaware Valley (MD, VA, DC)	CMS Sales & Marketing, Inc. 527 Plymouth Rd., Suite 420 Plymouth Meeting, PA 19462	(P) 215-834-6840 (F) 215-834-6848
Ohio Valley, Southeast	Giesting & Associates 2854 Blue Rock Road, P.O. Box 39398 Cincinnati, OH 45239	(P) 513-385-1105 (F) 513-385-5069
Minnesota, Iowa, North and South Dakota, Wisconsin	High Tech 4801 W. 81st Street, Suite 115 Bloomington, MN 55437	(P) 612-844-9933 (F) 612-844-9930
Northern California	Magna Sales, Inc. 3333 Bowers Avenue, Suite 251 Santa Clara, CA 95054	(P) 408-727-8753 (F) 408-727-8573
Southern California	SC Cubed 17862 17th Street, Suite 207 Tustin, CA 92680	(P) 714-731-9206 (F) 714-731-7801
Canada	Electro Source Inc. 230 Galaxy Boulevard Rexdale, Ontario, Canada M9W 5R8	(P) 416-675-4490 (F) 416-675-6871
Florida	PSA, Inc. 3537 Lakeview Blvd. Delray Beach, FL 33445	(P) 407-498-2029 (F) 407-499-7987